

**Basi statiche di bloccaggio, idrauliche, autocentranti – KSB**  
**Clamping force blocks, hydraulic, centric clamping – KSB**  
**Kraftspannblock, hydraulisch, zentrisch spannend – KSB**  
**Étaux de serrage, hydraulique, autocentreurs – KSB**



**Dati tecnici**

- Pressione d'esercizio: 120 bar
- Precisione di ripetibilità: KSB 210...250 0,03 mm  
KSB 310...380 0,05 mm  
con 100 cicli
- Temperatura d'esercizio: da 5°C a 60° C
- Sistema di funzionamento: cinematica a piani inclinati con guida forzata e trasmissione della forza applicata alle superfici
- Apertura/chiusura parallela con corse totali dei carrellini da 32 a 80 mm
- Applicazione tramite: fori per spine H7
- Materiale corpo: acciaio trattato
- Materiale parti funzionali: acciaio trattato
- Azionamento: olio filtrato (10µm) viscosità 46 mm<sup>2</sup>/s a 40° ISO VG; max 60° C;
- Attacchi: laterali - base
- Manutenzione: lubrificare tramite ingrassatori ogni 5.000 cicli in lavorazione, ogni 100.000 cicli con presa di manipolazione
- Optional: limitazione apertura, Rating IP54 (IP55), versione Z

**Technische Daten**

- Betriebsdruck: 120 bar
- Wiederholgenauigkeit: KSB 210...250 0,03 mm  
KSB 310...380 0,05 mm  
über 100 Zyklen
- Betriebstemperaturbereich: von 5°C bis 60° C
- Kinematik/Futterkolben: Keilhakenprinzip, für hohe kraftübertragung und zentrisches Spannen
- Parallel Öffnen/Schliessen, Gesamthub der Schlitten 32 bis 80 mm
- Ausrichten der Gehäuse durch Verstiftung H7
- Gehäuse und Funktionsteile aus gehärtetem Stahl
- Betätigung: hydraulisch über gefiltertes Öl (10µm) Viskosität 46 mm<sup>2</sup>/s bei 40° ISO VG; Max 60° C
- Druckluftanschlüsse: Über die Seitenflächen - Grundflächen
- Schmierintervalle: bei Einsatz auf Zerspanungsmaschine alle 5.000 Schaltspiele, bei Handhabungsprozessen alle 100.000 Schaltspiele.
- Zubehör: Begrenzung Öffnung, Rating IP54 (IP55), Version Z

**Technical data**

- Operating pressure range: 120 bar
- Repeatability accuracy: KSB 210...250 0,03 mm  
KSB 310...380 0,05 mm  
with 100 cycles
- Operating temperature range: from 5°C to 60° C
- Operating principle: wedge and piston design with mechanically restricted guidance
- Stroke range from 32 to 80 mm
- Mounting: by means of bores for H7 pins
- Housing material: hardened steel
- Material for functional parts: hardened steel <sup>2/5</sup>
- Actuation: filtered hydraulic oil (10µm) viscosity 46 mm<sup>2</sup>/s at 40° ISO VG; max 60° C
- Connections: sides - bases
- Maintenance: relubrified via lubrication-nipples, every 5.000 cycles for tool clamping, every 100.000 in handling
- Options: limitation opening, Rating IP54 (IP55), version Z

**Données techniques**

- Pression de service: 120 bar
- Précision de répétabilité: KSB 210...250 0,03 mm  
KSB 310...380 0,05 mm  
sur 100 cycles
- Température de service: de 5°C à 60° C
- Système de fonctionnement: piston et noix de commande à rampe
- Course parallèle des mors élevée de 32 à 80 mm
- Centrage par: trous pour goupilles H7
- Matière des pièces fonctionnelles: Acier trempé et rectifié
- Matière du corps: Acier trempé et rectifié
- Fonctionnement: huile filtré (10µm) viscosité 46 mm<sup>2</sup>/s à 40° ISO VG; Max 60° C
- Conduites: sur la côté - sur la base
- Maintenance: lubrification par graisseurs d'huile tous les 5.000 cycles avec serrage de pièces à usiner, les 100.000 cycles avec serrage de manipulation
- Accessoires: limitation de l'ouverture, Rating IP54 (IP55), version Z

**Basi statiche di bloccaggio, idrauliche, autocentranti – KSB**  
**Clamping force blocks, hydraulic, centric clamping – KSB**  
**Kraftspannblock, hydraulisch, zentrisch spannend – KSB**  
**Étaux de serrage, hydraulique, autocentrents – KSB**

**Version Z**  
**N ± 0,01**  
**to clamping center**  
**J ± 0,01**

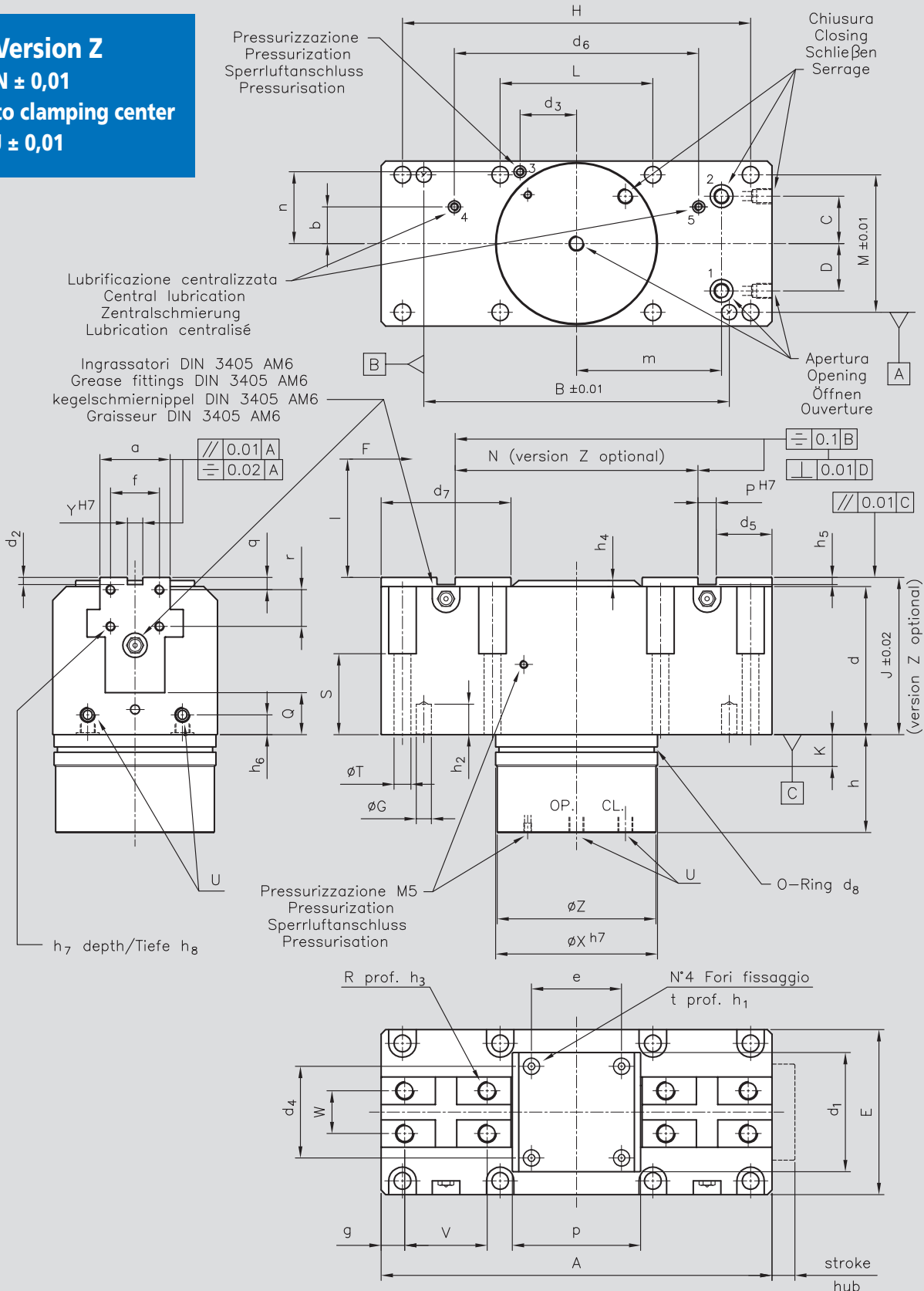

**Basi statiche di bloccaggio, idrauliche, autocentranti – KSB**  
**Clamping force blocks, hydraulic, centric clamping – KSB**  
**Kraftspannblock, hydraulisch, zentrisch spannend – KSB**  
**Étaux de serrage, hydraulique, autocentreurs – KSB**

Type	A	B	C	D	E	G	H	J	L	M	N	P	Q	R	S	T	U	V	Z	Y	X	K	W	a	b
KSB 210	210	156	17	26,5	96	8	186	91	86	82	130	14	24,5	M8	55	9	1/8	42	91,5	10	92	20	24	38	24
KSB 250	256	200	31	31	108	10	228	103	100	90	157	14	27,5	M12	53	11	1/8	54	105,5	10	106	20	28	46	24
KSB 310	310	240	35,5	35,5	128	12	280	120	120	108	182	20	32	M12	70	13	1/4	60	124,5	12	125	20	36	61	27,5
KSB 380	380	298	37	37	155	12	348	139	138	132	230	20	42	M16	80	13	1/4	70	148	16	149	25	40	70	46

Type	d	d <sub>1</sub>	d <sub>2</sub>	d <sub>3</sub>	d <sub>4</sub>	d <sub>5</sub>	d <sub>6</sub>	d <sub>7</sub>	d <sub>8</sub>	e	f	g	h	h <sub>1</sub>	h <sub>2</sub>	h <sub>3</sub>	h <sub>4</sub>	h <sub>5</sub>	h <sub>6</sub>	h <sub>7</sub>	h <sub>8</sub>	l	m	n	p
KSB 210	86	66	4,5	32	52	26	128	66	Ø 88,62 x 1,78	54	24	12	59,5	12	14	15	4	4,5	11	M5	10	32	82	40	76
KSB 250	97	78	5,2	37	60	35,5	160	85	Ø 101,27 x 2,62	59	32	15,5	64	12	20	22	4	5,2	13	M6	12	40	95	46	84
KSB 310	113	93	6,2	40	74	44	200	104	Ø 120,32 x 2,62	72	40	24	79	13	24	22	6	6,2	13	M8	16	45	115	56	100
KSB 380	130	110	8,2	47	88	55	210	130	Ø 142,50 x 3,53	83	50	30	87,5	17	24	28	7	8,2	16	M8	16	50	125	69	118

Tipo	q	r	t	Massa morsa (Kg)	Corsa per griffa (mm)	Forza di serraggio a 120 bar (N)	Lungh. Max griffe 60 bars 120 bar	Tempo circa idraulica (s) apertura chiusura	Consumo per doppia corsa (cm³)
Type	q	r	t	Mass Vise (Kg)	Stroke for finger (mm)	Clamping force at 120 bar (N)	Max jaw length 60 bars 120 bars	Approx. time hydraulic (s) opening closing	Consumed for double stroke (cm³)
Typ	q	r	t	Masse (Kg)	Hub pro Finger (mm)	Spannkraft bei 120 Bar (N)	Max fingerlänge 60 bars 120 bars	Schließzeit hydraulisch (s) Öffnen Schließen	Verbrauch pro Doppelhub (cm³)
Type	q	r	t	Masse étaux (Kg)	Course par morse (mm)	Force de serrage à 120 bar (N)	Longuer max morse 60 bars 120 bars	Temps environ hydraulique (s) ouverture serrage	Consommation pour double course (cm³)
KSB 210	7	25	M6	16	15	35500	170 85	1,5 1,5	135
KSB 250	7	25	M6	24	20	54800	280 140	2,3 2,3	252
KSB 310	9	28	M8	40	30	60600	330 165	3 3	402
KSB 380	10	36	M10	68	40	80500	460 230	3,5 3,5	708

- La forza di serraggio è la somma aritmetica delle forze individuali create alle griffe a "l" mm di distanza. I tempi di apertura e chiusura sono puramente i tempi che le griffe o morsetti sono in movimento.
- The clamping force is the arithmetic sum of the individual forces created at the top jaws at "l" mm distance. Closing and opening times are purely the times that the base jaw or fingers are in motion.
- Die Greifkraft ist die arithmetische Summe der an den Greifbacken auftretenden Einzelkräfte im Abstand "l" mm. Schließ- und Öffnungszeiten sind reine Rotationszeiten, dass die Grundbacken oder Finger in Bewegung sind.
- La force de serrage est la somme arithmétique des forces individuelles créées dans les mors à "l" mm distance. Serrage et temps d'ouverture sont les temps que le mors de base ou des doigts sont en mouvement.

**Connessioni dirette senza tubi**  
Hose-free direct connection

**Maße für schlauchlosen Direktanschluss**  
Connexion directe sans tuyaux

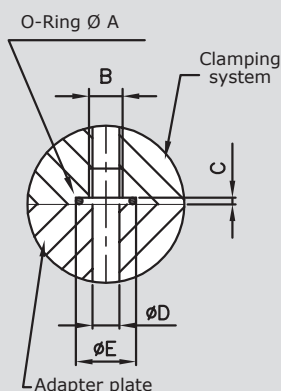

Tipo	1 and 2 Funzionamento Actuation Betätigung Fontionnement					3 Pressurizzazione Pressurization Sperrluftanschluss Pressurisation					4 and 5 Lubrificazione centralizzata Central lubrication Zentralschmierung Lubrication centralisé				
Type	A	B	C	D	E	A	B	C	D	E	A	B	C	D	E
KSB 210	Ø 10 x 1,5	M8	1	7	13	Ø 6 x 1,5	M5	1	4	9	Ø 6 x 1,5	M5	1	4	9
KSB 250	Ø 12 x 1,5	1/8	1	9	15	Ø 6 x 1,5	M5	1	4	9	Ø 6 x 1,5	M5	1	4	9
KSB 310	Ø 12 x 1,5	1/8	1	9	15	Ø 6 x 1,5	M5	1	4	9	Ø 6 x 1,5	M5	1	4	9
KSB 380	Ø 12 x 1,5	1/8	1	9	15	Ø 6 x 1,5	M5	1	4	9	Ø 6 x 1,5	M5	1	4	9

**Basi statiche di bloccaggio, idrauliche, autocentranti – KSB**  
**Clamping force blocks, hydraulic, centric clamping – KSB**  
**Kraftspannblock, hydraulisch, zentrisch spannend – KSB**  
**Étaux de serrage, hydraulique, autocentreurs – KSB**

**Dati di carico ammissibili sulle griffe**  
**Admissible jaws load**

**Maximal zul. Kräfte und Momente am Finger**  
**Données de charge admissible**

Tipo	CA max (N)	MR max (Nm)	MF max (Nm)	MT max (Nm)
Type				
Typ				
Type				
KSB 210	20000	120	230	210
KSB 250	26000	155	260	270
KSB 310	30000	175	290	310
KSB 380	42000	280	360	410

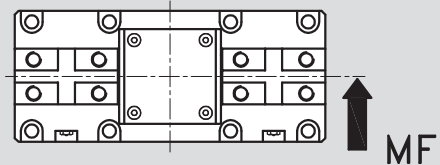
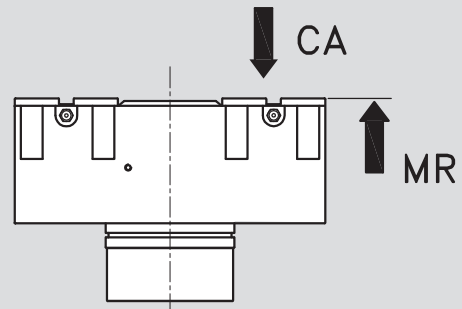
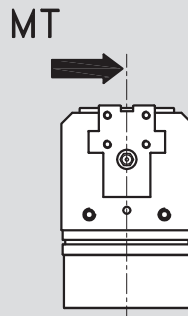

- Le forze e i momenti indicati sono valori statici applicati per griffa e possono occorrere simultaneamente.
- The indicated force and moment are static values apply for base jaw and may occur simultaneously.
- Die angegebenen Kräfte und Momente sind statische Werte, gelten je Grundbacke und dürfen gleichzeitig auftreten.
- La force et le moment indiqué valeurs statiques sont valables pour mors de base et peuvent se produire simultanément.

**Code PRA**  
**max 60 bars**

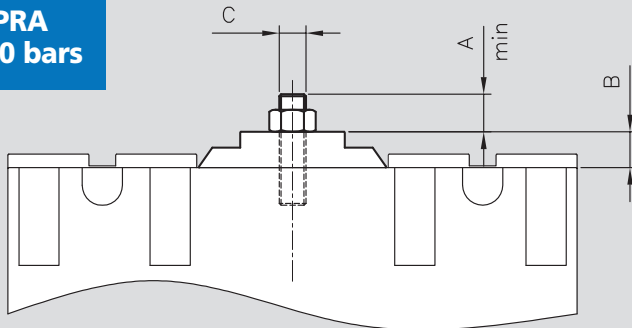

Type	A	B	C
Typ			
KSB 210	13	13	M10
KSB 250	17	16	M12
KSB 310	18	19	M16
KSB 380	27	23	M20

- Limitazione apertura codice PRA - max 60 bars.
- Limitation opening - code PRA - max 60 bars.
- Begrenzung Öffnung - Code PRA - max 60 bar.
- Limitation de l'ouverture - code PRA - max 60 bars.

**Code HIP**  
**Rating IP 54**

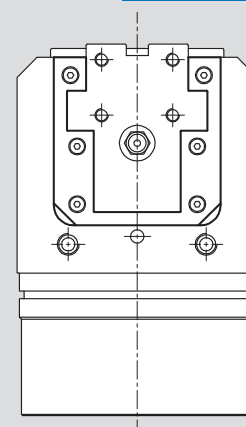

(IP 55 with pressurization and O-Ring inside the cover)

**Esempio d'ordine - Ordering data**

**Bestellbeispiel - Exemple de commande**

Tipo	Versione Z	Limitazione aperture cod. PRA	Rating IP 54 cod. HIP
Type	Version Z	Limitation opening code PRA	Rating IP 54 code HIP
Typ	Version Z	Begrenzung Öffnung Code PRA	Rating IP 54 code HIP
Type	Version Z	Limitation de l'ouverture code PRA	Rating IP 54 code HIP
KSB 250	Z	PRA	HIP